



TIGER LIFT ELEVATORS DESIGN AND PLANNING GUIDE

Elevator Concepts' TIGER LIFT series of elevators is designed to meet the need for small, high quality, and economical elevators in a variety of applications. This extensive and versatile product line can fit just about any site plan and budget. Several platforms are designed to accommodate modifications to allow for extensive customizing. This Design and Planning Guide has been prepared to help you choose the right TIGER LIFT for your application.

Why choose a TIGER LIFT? We know there are other elevator manufacturers that want your business. Here are several reasons why choosing the TIGER LIFT line of small elevators is the best choice you can make:

WE'RE SPECIALISTS

Elevator Concepts has been designing and manufacturing small elevators exclusively since 1985. We have the experience to manufacture cost competitive standard units as well as highly customized special units.

WE INSIST ON QUALITY

We design our own equipment in house - you will not see copycat engineering in a TIGER LIFT. Component parts utilized in our elevators come only from the finest suppliers in the industry. We are not the least expensive elevator manufacturer; we are the highest quality manufacturer. While price is important, you won't be thinking about the bargain you got when you're having trouble with the equipment.

WE GIVE YOU MORE CHOICES

There are more options available for TIGER LIFT elevators than any other small elevator product line. If you need an option or configuration that you don't see in this guide, we'll be happy to investigate the possibilities of supplying it. Customer suggestions play an important role in our ongoing process of improvement. Custom designs are our specialty.

WE DELIVER GREAT VALUE

We know that there are alternatives when looking for access solutions. You'll find that dollar for dollar, a TIGER LIFT will provide more use than other types of access devices. Most people prefer the security and comfort of a fully enclosed elevator car over an open platform lift. The investment made in a fully enclosed elevator will result in more usage than a similar investment in a platform lift.

WE DELIVER GREAT SERVICE

We build the best elevator possible at the best possible price. If you have any problem with a TIGER LIFT, it is our problem too. We support our products - our commitment is just beginning when the elevator leaves our plant. Our goal is to deliver a complete elevator that installs easily and functions properly. We meet that goal the vast majority of the time, but if we fail in any respect, we will do whatever it takes to satisfy you. No questions asked.

TIGER LIFT PRODUCT LINE
COMMERCIAL SERIES

TYPE I

This is the original basement traction TIGER LIFT. It incorporates many innovative design features that make it well suited for many situations, especially retrofit applications. Among its unique features:

- Unique structural tower arrangement for guide rails and machine, allowing for very little loading on hoistway walls - load is transmitted to pit slab.
- Governor operated overspeed safety
- 3 3/8 - 8x19 hoist cables
- Machine and governor located at bottom of hoistway, eliminating the need for penthouses, ladders or other elaborate means of equipment access.
- All equipment is can be located within the hoistway; controller can be remotely located if desired.
- Requires only 20 amps of 115 VAC single phase current

The Type I is the most expensive TIGER LIFT, but the savings in building construction in many instances will more than make up the difference compared to a less expensive model. The Type I allows for many different cab configurations and equipment options.

TYPE X3C

This is the direct hydraulic version of our pre-engineered series. It features our newest frame design, which is made from formed steel sections. It is available in 750# and 1400# capacities, and several cab sizes. Pre-engineering means shorter lead times and lower costs.

TYPE X5C

This is the roped hydraulic version of our pre-engineered series. It is similar to the X3, with the addition of a rope sheave, follower guides, and broken cable safety. It has performance characteristics similar to the Type X3, but does not require a well hole for the hydraulic cylinder.

The X3C and X5C are standard production units and should be specified when possible.

TIGER LIFT PRODUCT LINE
RESIDENTIAL SERIES

The residential series offers the same dependability and innovative designs of our commercial elevators, but are designed for the less rigorous demands of residential duty to offer cost savings. Primary differences include lighter gauge frame components, 8# T rails on the R1D, stile mounted guides, lower capacity and speeds, and restrictions on some options. Our residence elevators should not be confused with light duty units, which typically have a unichannel guide rail with trolley which requires a 3rd stabilizer rail.

TYPE XD

This is a drum machine based on our new lightweight frame. It is our least expensive model, but should not be confused with other inexpensive drum machines on the market. This unit utilizes "T" rails on 28" centers to provide stability without having to add on "optional" 3rd rails. It features up to 40' travel, 500# or 90# capacity, variable frequency drive for an extremely smooth ride, and instantaneous broken rope safeties.

TYPE X3R

This is a direct hydraulic model incorporating our lightweight frame. It features a 750# capacity, submersible screw pump unit, 28 FPM single speed valve, leveling/anticreep operation, and several cab sizes. A partial well hole is required for the hydraulic cylinder. Many options are available

TYPE X5R

This is a roped hydraulic model, incorporating our lightweight frame, instantaneous broken rope safety, and a hydraulic cylinder fitted with a rope sheave and follower guides. It has performance characteristics similar to the Type X3R, but does not require a well hole for the hydraulic cylinder.

If your requirements exceed the capabilities of our residential series, one of our commercial elevators can be adapted to your requirements.

TIGERLIFT OPTIONS

The TIGER LIFT line of small elevators comes with a number of features in their standard configuration; this standard configuration is designed to be a complete package with all equipment required for an installation designed to meet most code requirements. The TIGER LIFT line has a wide range of options available to satisfy specific owner needs and code requirements. The options described below are operational in nature, and deal with function instead of appearance. There are numerous options for cab and fixture appearance; it would be impossible to list these. If you have an option in mind that is not listed, please consult the factory for availability - most likely we have done it before.

TRACTION MACHINES:

TYPE I MACHINE - basement mounted machine assembly, with necessary overhead framework, deflector sheaves, and basement governor. Used where overhead space is limited or not accessible.

SOFT START - a VVVF motor drive, designed to provide a smooth start when using the standard single speed AC motor. Recommended for most applications.

HYDRAULIC MACHINES:

ROPED HYDRAULIC: a hydraulic cylinder with cable and sheave arranged for a 1:2 lift ratio. Used where drilling a well hole or providing extra overhead is not possible.

SAFETY: safety mechanism used where required by code to stop elevator in case of normal drive system failure. Typically required on roped hydraulic.

GEAR PUMP: a pump using gears instead of a screw. This is a deduct option; used where quiet operation is not required.

RUPTURE VALVE: a variable orifice at the jack inlet which is held open by system pressure. When system pressure drops suddenly, such as a line or hose failure, the valve closes the orifice to allow a controlled stop.

TANK HEATER: a 75 watt thermostatically controlled submersion heater to keep hydraulic fluid from getting too cold. Used where machine room temperatures will drop below 50 degrees.

AUTO LOWERING: a special valve, control circuit, and battery power supply which will allow the elevator to descend to the lowest level in the event of a power failure. Can be designed for automatic or push-button operation.

TWO SPEED VALVE: a valve and related control circuitry used for speeds above 35 FPM. Used primarily in applications with travel exceeding 25 feet.

PG-001 Planning guide

GENERAL OPTIONS:

MICROPROCESSOR: A PLC based control instead of a relay control. The majority of TIGER LIFT elevators have simple control requirements which are handled with a relay control. Microprocessor control is used for custom units with complex control functions, or to meet a specification.

HARDWIRE - all wiring, including low voltage, in conduit. Used where required by code.

RETIRING CAM: device used to operate true door interlocks. Used where required by code.

DOOR MONITOR: a buzzer which sounds when a call button is pushed, but the car cannot run because a door or gate is open.

ARRIVAL GONG: a gong which sounds as the car stops at a landing.

ARRIVAL LIGHT: a light which activates as the car stops at a landing.

ILLUMINATED BUTTONS: a translucent button which illuminates when a call is entered; light extinguishes when call is complete.

KEY SWITCHES: used in place of or in conjunction with call buttons. Used for security or where required by code. Many variations possible - contact the factory for specific applications.

IN USE LITE: used in conjunction with key switch to show that call has been registered.

CAR TOP STATION: used to operate unit from on top of car. Used where required by code or when desirable, usually on higher rises.

FIRE SERVICE: recalls car to main floor. Used where required by code.

AUTO DOOR: Control circuitry to automatically activate a power hoistway door opener when the car reaches the landing. Power hoistway doors and/or operators can be supplied by us, or we can provide circuits to interface with your equipment.

AUTO LIGHTS: Control circuitry to automatically activate the regular car lights when a door is opened, and shut them off after an adjustable length of time.

EMERGENCY LIGHT: low level cab lighting which comes on automatically during power failure.

SCISSOR GATE: "Bostwick" style collapsing gate.

SIDESLIDE GATE: Solid panel gate which does not collapse, but rolls around the side of the car.

GATE OPERATOR: Power operation for either the standard woodfold gate or the sideslide gate option.

ESCAPE HATCH: Removable roof section for emergency access to cab. Used where required by code.

TRAVEL RESTRICTOR: Required by Section 25 LULA code when pit is less than 36" or overhead is less than 136"

HORIZONTAL SIDESLIDE ENTRANCES: Traditional elevator style entrances and frames.

With so many models to choose from, it may seem difficult at first to make the best choice for a particular application. As with any guideline, this brief explanation is not intended to cover every single design application question, but rather be a guide. In some cases a standard model will not fit the application. Whenever you have any application questions, give us a call!

The first question to answer when selecting an elevator is " What exactly do we expect the elevator to accomplish for us?" This can be broken down into several more specific questions, which are appropriate for all types of elevators:

- How much weight must it lift?
- How fast should it lift it?
- How many landings will be served?
- How large does the cab need to be? (how big are the things going on the elevator?)
- Are automatic doors or gates required?

There will probably be several different models to fit the bill based only on the answers to these questions. Next, we have to answer questions about the building structure that will support the elevator:

- What size is the hoistway?
- What is the wall construction?
- How deep is the pit?
- How high is the overhead?
- What kind of power is available?
- Is a machine room available?
- Is an overhead machine space available?
- How many car openings are required to suit the floor plan?
- Is underground drilling a problem?

These answers will usually narrow the available choices down. Finally, we establish which options are desired and available. This leaves us with the final choices available. At this point, the selection is generally determined by price. To generalize, we offer these broad guidelines:

Drum machines Our overhead drum machine eliminates the problems typically associated with winding drum residential elevators: noise, ride quality, structural machine room floor; and safety concerns if the motor contactor welds shut. Elevator Concepts LTD drum machines start with a highly efficient helical bevel gearbox, which is compact, powerful and quiet. With as little as 8' at the top landing, we can mount the machine on top of the guide rails – eliminating a separate machine space and the structural requirements for attaching it. Our new programmable controller controls the machine, with variable frequency drive for extremely smooth stops and starts and many safety features. An optional battery backup emergency lowering system is available.

Hydraulic machines are have gained wide acceptance in all applications, from residential to heavy duty freight. In the TIGER LIFT line, we offer both direct and roped hydraulic. Direct hydraulics are less expensive, but most require a well hole for the hydraulic cylinder. For applications with travel 12' or less, the well hole is generally not a problem, and the direct hydraulic is the most cost effective. For applications exceeding 12', or where site conditions preclude a well hole, the roped hydraulic is usually the most cost effective, as the added expense of the roped mechanism is usually less expensive than providing the well hole. Hydraulic elevators are fail-safe with regard to electrical system failure. Ride quality is excellent thanks to modern control valves. Submersible pumps make for very quiet operation, equivalent to a pool filter pump. Hydraulic machines require 220 power, a separate machine space, and at least one load bearing hoistway wall. While a hydraulic requires a lot of electrical power to go up, it requires none at all to go down. This inherent characteristic makes it very easy to move a hydraulic elevator during a power failure.

Traction machines are the most expensive, all other things being equal. Traction machines are much more efficient, requiring only half the electrical power of a drum or hydraulic. TIGER LIFT traction elevators run on 115 volt current. Other advantages include no separate machine room and no need for heavy structural walls. In some applications, the cost to provide 220 power, or a machine room, or structural walls outweighs the additional cost of the traction unit. Traction elevators are also fail-safe with regard to electrical system failure. Traction equipment generally requires less maintenance than hydraulic equipment.

While each type of drive requires different types of maintenance and safety tests, overall cost of maintenance of all types tends to be fairly equal over the long run. Elevator Concepts LTD recommends maintenance inspections on a quarterly basis as a minimum, regardless of the type of elevator. Local code may require a different frequency. For cars with a safety, we recommend a no load test every year, and a full load test every 5 years. For cars with buried hydraulic equipment, we recommend that the cylinder be tested every year. Hydraulic pressure relief valves should also be tested every year.

A winding drum or roped hydraulic machine in terms of both performance and price best serves the majority of residential installations. For LULA elevators, hydraulics are the most appropriate, with a direct hydraulic is most cost effective for elevators with less than 12' of travel, and a roped hydraulic for elevators over 12 feet.

Typical layout drawings for LULA and residential applications are available in this guide. It is not possible to depict every possible configuration in a planning guide of this type. Hoistway sizes, car sizes and landing configurations are available in a wide range for each type of elevator. Custom sizes and configurations to overcome existing site limitations are also possible. The chart following the drawings summarizes the characteristics of each model of the TIGER LIFT line.

For LULA and automatic "traditional" elevator type sliding door applications, we recommend using either direct or roped hydraulic models.

If you can build your hoistway to suit, you can take advantage of the savings available with our pre-engineered "X" series. If your job conditions will not accommodate a standard X series unit, we can build a TL series unit to suit.

Codes and designs are subject to change without notice. Before committing to design or construction, consult with your elevator contractor, or contact our engineering department.

**TIGER LIFT ELEVATORS
DESIGN & PERFORMANCE DATA**

	TLI	X3C	X5C	XD	X3R	X5R	X4R
MACHINE TYPE	Trac	Hydro	Roped	Drum	Hydro	Roped	Trac
MAXIMUM CAPACITY	850	1400	1400	950	750	750	750
STATIC CAPACITY	7000	7000	7000	3800	3800	3800	3800
MAXIMUM PLATFORM	36X60	42X60	42X60	36X54	36X54	36X54	36X54
MAXIMUM STOPS	8	4	4	4	4	4	4
MAXIMUM TRAVEL	50	15	50	35	18	50	50
SPEED	32	28	28	35	28	28	32
POWER REQUIREMENT	115	220	220	220	220	220	115
MINIMUM PIT	12"	12"	12"	8"	8"	8"	8"
MINIMUM OVERHEAD	9'	9'	9'	9'	8'	8'	8'
GROSS PIT LOAD	3500#	2500#	2500#	2300#	2000#	2000#	3000#
GROSS BRACKET LOAD	25#	300#	300#	300#	300#	300#	300#
RAIL SIZE	8#	8#	8#	8#	8#	8#	8#
MAXIMUM CAR GATES	3	2	2	3	2	2	2
BUFFERS	STD	STD	STD	STD	STD	STD	STD
STEEL GATES	OPT	OPT	OPT	NA	OPT	OPT	NA
VVVF DRIVE	OPT	NA	NA	STD	NA	NA	OPT
2 SPEED VALVE	NA	OPT	OPT	NA	OPT	OPT	NA
OPTIONAL HIGH SPEED	NA	50	50	NA	50	50	NA
AUTO DOORS/GATES	OPT	OPT	OPT	OPT	OPT	OPT	OPT
SIDESLIDE ENTRANCES	NA	OPT	OPT	NA	OPT	OPT	NA

You won't find a "typical" shop drawing for every model in this guide because we don't believe there is a "typical" elevator. Elevator Concepts LTD manufactures the widest array of pre-engineered and custom small elevators available, and can supply just about any imaginable combination of configuration, fixtures, finishes, and options. It would be impossible to put them all in this guide. Even if we could, it would be difficult for most people to determine the right plan to use.

We provide working drawings for architects and engineers upon request. By spending just a few minutes with you early in the design process, we can save you a lot of time and trouble by providing just the right information. Please contact us to request working drawings.

In the back of this guide, you will find sample hoistway plans for our most popular pre-engineered sizes. Using a pre-engineered system will save you time and money.

Before you use any information contained in this guide for design or construction, please consult us. Code and design changes can make this information obsolete at any time!

TIGER LIFT STANDARD SPECIFICATIONS
GENERAL SPECIFICATIONS**CAR FRAME:**

Frame shall be constructed of steel, rigidly reinforced and gusseted, bolted and welded to insure durability including steel crosshead, safety plank, platform beams, stringers, side stiles, buffer strikes, and mounting pads for guide shoes. Provide cable hitch and safety actuating mechanism where applicable. Provide reinforced adjustable platen assembly for hydraulic units. Platform shall be 1-1/4" thick plywood. The entire car frame assembly shall be capable of sustaining a minimum static load of 5, or greater as required by code.

GUIDE RAILS:

Steel T rails shall be machined to exact tolerances for smooth travel. Guides shall be stabilized by adequate adjustable steel brackets as required, and secured to hoistway with suitable fasteners. Guides shall have a nominal weight of 8 lbs/ft.

GUIDE SHOES:

Adjustable car guides shall be fitted to the frame, and shall the rail with a minimum of clearance. Insert shall be nylon with molybdenum disulfide machined for close tolerance. Insert shall be removable without removing entire shoe. Where applicable, counterweight guide shoe to be rolled steel welded to an adjustable base. Inserts shall be nylon, machined for close tolerance. Insert shall be removable without removing entire shoe.

BUFFERS:

Compression springs of sufficient stroke and capacity shall cushion the car and counterweight in the event of overtravel.

CONTROLLER:

Controller shall be enclosed in a NEMA 12 cabinet. Controller shall be of the electro-magnetic type, designed to prevent damage to the motor from overload or excessive current. The controller shall automatically stop the motor and set the brake if any safety device becomes operative. A non interference relay shall be provided. Momentary pressure on a car or hall button shall send car to the desired floor if all safety circuits are made up.

CAB:

Cab walls to be 3/4" engineered stressed-skin panels, consisting of high pressure plastic laminate pressure bonded with epoxy to a high density frame with 0-0-10 3/8 verticel core material. When required, car shall be fitted with a collapsing gate at each opening, conforming to applicable code. Canopy shall be 3/4" stress skin panel, laminate finish with 2 recessed incandescent light fixtures. Canopy shall be capable of sustaining 100 lbs/sq.ft.-(500 lbs total. Provide emergency bell and handrail.

GATE:

Standard gate to be wood folding accordion type, with concealed spring hinges. Panels to have stabilized wood core faced with semi-rigid vinyl film, 6 mil minimum, pressure laminated. Natural wood veneer optional. Hanger assembly of dual nylon rollers shall be installed on alternate panels. Gate shall be suspended in track of no less than 20 gauge metal. Gate shall be fitted with lower guide pins and track. Optional gate operator shall be a traction drive type, consisting of a DC gearmotor close coupled to a 3-1/2" traction sheave, adjustable deflector and tensioning sheaves, magnetic open and close limits, and 1/8" steel aircraft cable with gate attachment, all mounted on an adjustable aluminum base.

Optional side slide gate to consist of articulated 5" panels, each consisting of a) 2 interlocking sheets of 18 gauge steel for a total panel thickness of 5/8" or b) solid red oak. Each panel to have articulation joint with upper and lower bearings, retaining rod and outer tube. Provide 3 wheel trolley with ball bearing urethane tired wheels on alternate panels. Provide nylon bearings for bottom guide. Provide upper and lower aluminum extruded track, with molded corner sections. Gate to turn and recess behind cab wall. Power operator also available.

FIXTURES:

Provide a car operating panel with illuminated buttons for each landing. Provide a light switch, alarm button, and emergency stop button. Provide an illuminated call button at each landing. All fixtures shall have stainless steel face plates, #4 finish.

PG-001 Planning guide

TRACTION ELEVATORS

MACHINE:

Double reduction bronze ring and worm gear machine mounted on a structural steel base. Motor shall be face mounted, totally enclosed fan cooled. Motor shall be 1750 RPM single speed AC, with integral brake, 6 ft/lbs capacity, spring set, electric release. Optional variable voltage drive shall consist of a heavy duty permanent magnet field motor and a solid state adjustable SCR drive, with minimum and maximum speed adjustment, line start and stop, line voltage compensation, full wave armature supply, adjustable current limiting, adjustable acceleration and deceleration, adjustable I.R. compensation, and temperature compensation.

COUNTERWEIGHT:

Provide sufficient weight to balance car. Frame shall be steel, of welded and bolted construction. Provide two tie rods to bind weights.

DRIVE AND DEFLECTOR SHEAVES:

All sheaves to be cast iron precision groove type, fitted with tapered bushings for secure fastening. All sheave shafts to be fitted with self-aligning pillow block ball bearings. Deflector sheaves shall be grooved to support cable without deformation. Drive sheave shall be grooved to maintain sufficient traction under operating conditions, but break traction upon setting safeties or overtravel into buffers.

GOVERNOR AND SAFETY:

Type A instantaneous safety shall be located in a steel safety plank below the platform, capable of stopping and holding the car plus its rated load with a safety factor of 5 minimum. Governor shall be of the centrifugal type, tripping at 125-175 fpm. The governor rope shall be steel, 1/4" diameter and 8x19 construction. Governor shall be located on the machine base. Tension sheave shall maintain sufficient traction, and be located in the overhead. Safeties shall set through inertia on free fall, independent of the governor. Safety shall operate a switch to remove power from motor and set brake. Safety shall release by raising the car.

HYDRAULIC ELEVATORS

MACHINE:

Pumping unit to be of unitized construction, including steel reservoir of adequate capacity with filler, strainer, sight gauge and magnetic drain plug, direct coupled gear type positive displacement pump, heavy duty motor externally flange mounted for ease of service, and unit valve and line shut off valve.

PUMP:

Standard pump shall be high tolerance 3 screw set of hard nitrided steel, balanced to eliminate all axial loading. Input shaft to be supported by motor grade roller bearing. Housing to be extruded from G-Al-Si-12 Cu-Mg-Ni alloy, with integral steel strainer.

VALVE:

Hydraulic unit control valve shall be machined from solid aluminum billet, with the following field adjustable functions: check valve, relief valve, up start valve, down start valve, down stop valve. Unit valve shall be equipped with self closing manual lowering valve, self cleaning strainer, pressure gauge & shut off.

LEVELING DEVICE:

Provide automatic 2-way leveling device to maintain platform within 3/8' of landing. Leveling device to function when doors and gates are open or closed.

JACK UNIT:

The hydraulic jack unit shall comply with all provisions of ANSI 17.1. The plunger will be machined true to a minimum smoothness of 12 micro-inches, and equipped with a suitable stop ring. The cylinder will be rated for 500 psi working pressure, and fitted with a safety bulkhead, seamless dished bottom cap, removable head, bearing, and packing, and provisions for air bleed and leakage collection.

PG-001 Planning guide

ROPED UNITS:

The jack unit shall be equipped with a U-groove sheave to support hoisting cables. Sheave shall be mounted in a steel yoke and secured to plunger. Yoke shall be equipped with guide assembly to follow guide rails. Hoisting cables to be 3/8" x 8-19 traction steel, and shall terminate in wedge clamp type fasteners.

Type A instantaneous safety shall be located in a steel safety plank below the platform, capable of stopping and holding the car plus its rated load with a safety factor of 5 minimum. Safety shall be actuated by a slack cable mechanism or optional governor. Safety shall operate a switch to remove power from motor and valve. Safety shall release by raising the car.

WINDING DRUM ELEVATORS:

DRUM MACHINE:

Single reduction bronze ring and worm gear machine mounted on a structural steel base. Motor shall be face mounted, totally enclosed fan cooled. Motor shall have close coupled disc brake, 6 ft/lbs capacity, spring set, electric release. Machine shall be located as per job requirements. Drum shall be fabricated of DOM tubing, with accurately machined grooves to guide and support the hoist cables. The drum shall be fitted with tapered bushings in each hub to facilitate installation and removal. The drum shall have provisions to retain the free end of the hoist cables. The drum shaft shall be supported by an outboard pillow block roller bearing. Machine shall have an adjustable limit switch to remove power from motor and brake in the event of overtravel in either direction.

DRUM DEFLECTOR SHEAVES:

Deflector sheave shall be 6" steel, grooved to support cable without deformation. Sheaves to be fitted with bronze sleeve bearings. Traveling deflector sheave shafts shall be rigidly supported and sized to allow minimal deflection.

OPTIONAL EQUIPMENT:

DC DRIVE:

DC Drive shall consist of a special permanent magnet DC motor with a solid state speed control which contains adjustments for linear acceleration, linear deceleration, current limit, IR compensation, maximum and minimum speeds. Drive shall have temperature, IR, and line voltage compensation to provide 1% base speed regulation.

SOFT START:

Soft start shall be a solid state SCR network that shall gradually increase motor torque. Separate adjustments for time and torque shall be provided.

RUPTURE VALVE:

Rupture valve shall be mounted directly to cylinder inlet. In the event of pressure loss in hydraulic system ahead of valve, the valve shall close and bring the car to an immediate controlled stop. The valve shall be field adjustable to close at 10% under no load pressure, and shall open automatically when either the load is removed from the cylinder or pressure is restored to the hydraulic system. A flow control valve will not be an acceptable substitute.

TANK HEATER:

Heater shall be of the surface mount type, thermostatically controlled to automatically maintain oil temperature.

AUTO LOWERING:

Provide circuitry and auxiliary power supply to allow car to descend to lowest landing in the event of failure of the main power supply. All safety circuits shall be fully operational. Provide circuitry to allow for either automatic or passenger initiated descent of car.

2 SPEED VALVE:

Hydraulic unit control valve shall be machined from solid aluminum billet, with the following field adjustable functions: check valve, relief valve, up start, up transition, up leveling, up stop, down start, down speed, down transition, down level, and down stop. Unit valve shall be equipped with self closing manual lowering valve, self cleaning strainer, pressure gauge & shut off.

PG-001 Planning guide

MICROPROCESSOR:

Optional programmable controller shall have 12 I/O; 1194 word RAM/ROM; EPROM program backup; I/O expandable to 140; ON/OFF, CPU OPERATION, POWER-RUN, ALARM, & ERROR indicators, integral power supply, 10 usec per instruction execution time.

RETIRING CAM:

Heavy duty parallel arm gravity-drop cam with sufficient weight to open interlock, with torque motor to raise cam to lock door.

SCISSOR GATE:

Collapsing gate shall be heavy duty Bostwick type, with a minimum of 11 stiles and a minimum of 2 sets of relating scissors. Gate shall conform to all applicable requirements of ANSI 17.1. Stiles shall be fabricated from rolled steel channel. Relating scissors shall be fabricated from 1/8" steel flat stock. Gate shall be suspended on every other stile by a 3 wheel truck assembly, with provisions for height adjustment. Wheels shall be ball bearing type with polyurethane tires. The bottom of each stile shall be fitted with a nylon guide. The entire gate assembly shall be coated with enamel.

AUTOMATIC CLOSER:

Gate shall be designed to close automatically after a field adjustable time delay. Closer shall be of the spirator type, with winding reel and aircraft cable with suitable attachment. Winding reel shall have provisions for retention by an adjustable solenoid, activated by the time delay circuit.

GATE OPERATOR:

Operator shall be traction drive type, with DC gearmotor, traction sheave, adjustable deflector sheaves, adjustable open and close limits, and control unit with DC power supply. Open and close speeds shall be fully adjustable. Traction drive shall be adjustable to provide for loss of traction if gate is obstructed. Signal from main control shall actuate open or close operation. Optional reopening device shall stop gate from closing and return it to the open position.

SWING DOOR OPERATOR:

Mark IV by Door Motion Technologies. Electromechanical type utilizing parallel arm pull type actuation. Operator shall be mounted on hoistway door. Integral spring closer, adjustable opening speed and back check.

AUTOMATIC HORIZONTAL SLIDING DOORS

Car and hoistway doors shall open and close simultaneously at all levels. Door movement shall be fully adjustable, cushioned at both limits of travel. Operating mechanism shall be arranged to allow manual opening during loss of electricity when car is in the unlocking zone. Hoistway doors shall be self-locking and self-closing at all times.

Provide new door hangers and tracks. Hangers to be sheave type, no less than 2 per door, tired with a suitable sound reducing material and shall rotate on sealed ball bearings. Provide adjustable means to eliminate upthrust. Make modifications to existing doors and headers as required to accommodate hangers and tracks. Provide manufacturer's standard door closing device. Provide new sills, sill supports, struts, headers, frames, and door panels as required for a complete installation. Finish as specified above.

A solid state infrared door reversal device shall be installed on all car doors. The device shall be capable of detecting an opaque ball 1" in diameter anywhere in the within its path. Upon detection, the doors shall stop and reopen, after which the door shall again start to close. If the door is prevented from closing for approximately 30 seconds, the doors shall close at a reduced speed ("nudging"), regardless of the condition of the reversal device.

Provide 16 gauge hollow metal doors and 14 gauge frames finished as specified. Provide aluminum sill with guide groove for non-metallic bottom gibb. Provide mechanical spring type closing device for each entrance. Provide struts, headers, fascia, toe guards, hanger covers and hardware as required.

Elevator Concepts LTD continually improves its products, and reserves the right to modify these specifications at any time without prior notice. Please check with us or an authorized TIGER LIFT dealer before incorporating any specifications or dimensions in working construction documents. We are happy to review your documents at any time and will provide specifications tailored to your requirements at no charge.

TIGER LIFT & CODES

TIGER LIFT elevators, as manufactured by Elevator Concepts LTD, are limited use - limited access elevators, and do not comply with ADA and ASME A17.1 Section 2 & 3 requirements for full passenger elevators. TIGER LIFT elevators, properly specified, will meet the ASME A17.1 Section 25 - Limited Use/Limited Access Elevator code. There is speculation that the ADA will recognize LULA's for certain applications, but this would certainly be several years away. The TIGER LIFT currently meets many State and local requirements for LULA type devices.

The Section 25 LULA code allows for these basic parameters:

MAXIMUM LOAD	1400#
MAXIMUM SPEED	30 FPM
MAXIMUM PLATFORM	18 SQ FT
MAXIMUM TRAVEL	25 FT

TOP AND BOTTOM CLEARANCES AS PER Section 1 (typically 3' pit and 11' overhead minimum)

The addition of car top inspection, retiring cams, and flush type hoistway doors are generally all that is required to make a standard TIGERLIFT comply with Section 25, unless there are restrictions on top and bottom clearance. In those cases, electro/mechanical travel restrictors are required. Several jurisdictions currently use this; others are either more or less restrictive.

The Americans with Disabilities Act is civil rights legislation designed to promote the removal of barriers. It is not a building code; technically, it does not require anything be done to any building. If buildings are not in compliance with the ADA, the Department of Justice can bring suit against the building owner, with penalties including making the building comply with ADA along with substantial fines. However, most of the model building codes such as BOCA now have design requirements patterned after the ADA., so new construction and renovation work will typically comply with ADA if it complies with the building code.

For new construction, or improvements to existing structures, the ADA does not required a full passenger elevator if a building has less than 3 stories, or if each story in the building is less than 3000 square feet, unless the building is a shopping mall, a medical office, or other type of building the government determines should have an elevator. If a full passenger elevator is planned for a building, whether required or not, it must meet the ADA requirements for elevators and serve every level, unless it is infeasible to do so. However, the ADA does not prohibit the installation of devices other than full passenger elevators in buildings where there is no requirement for vertical access. Since the TIGER LIFT is not a full passenger elevator, it is not subject to the requirements for a full passenger elevator when installed in buildings such as described above.

The ADA specifically allows platform or wheelchair lifts meeting local codes to be used to provide access to a performance area, to a specified wheelchair viewing area, incidental spaces for less than 5 people not open to the general public, and **areas where it is infeasible to provide a ramp or an elevator.**

All codes are subject to interpretation and revision. It is always advisable to check with the code enforcement authority with jurisdiction about the latest requirements. The information contained herein, while believed to be accurate, is provided for general reference purposes only. **Changes occur in Codes regularly.** Elevator Concepts is not responsible for any condition arising out of the use of the information provided herein.

Sample Plan Views Do Not Use For Construction

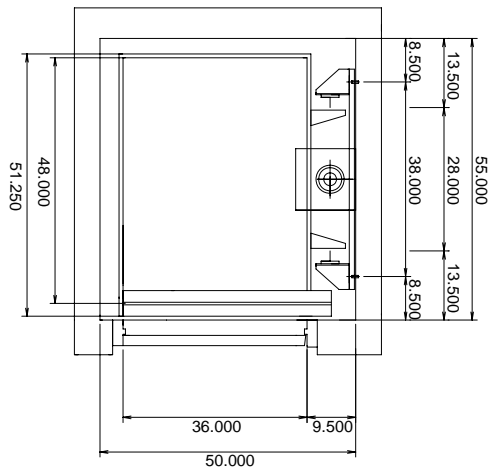

1 Accordion Gate

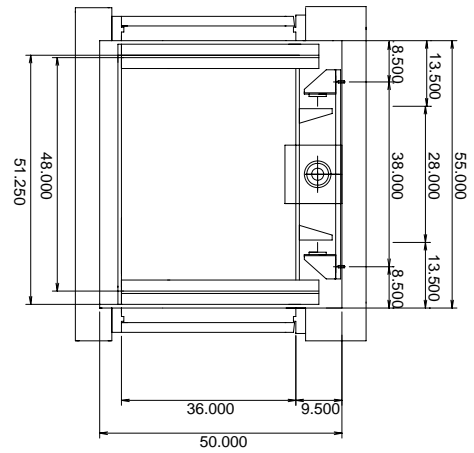

2 Accordion Gates

RESIDENTIAL
36" x 48" CAR SIZE

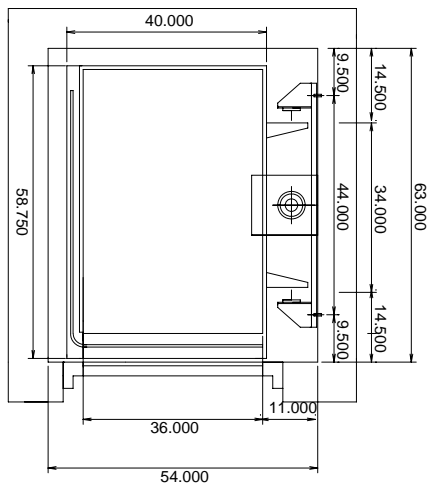

Wrap Around Gate

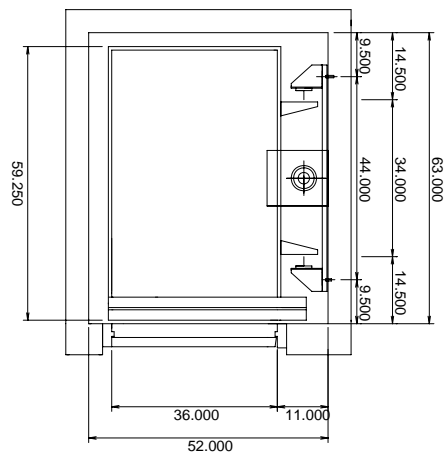

Accordion Gate

LULA
36" x 54" CAR SIZE

**Sample Plan Views
Do Not Use For Construction**

Wrap Around Gate

LULA
42 x 60 CAR SIZE
MANUAL DOORS

Accordion Gate

LULA
42 x 60 CAR SIZE
POWER DOORS
